

PRIMARY USES

Used worldwide by jewelers and financial institutions for inventory storage, safekeeping, layaways, customer items, negotiable documents and cash storage.

FEATURES & BENEFITS

DOOR . . .

- 5 $\frac{1}{16}$ " combination steel and high density stress-resistant composite material with welded-in hinges and built-in locking mechanism.
- Other protective devices against thermal attack and explosives such as heat fuse link and relocking bolts.

BODY . . .

- 4" total body thickness includes special, high density, stress-resistant composite material.
- Precision-formed and electrically-welded construction throughout.

LOCKS . . .

- Multiple, heavy steel sliding bolts engage vertically and horizontally into body structure.
- Large, floating glass plate activates randomly located relocking devices in event of major attack.
- Lockable interior door conceals lock mechanism.
- Standard equipment includes both high-precision keylock and 3-wheel, Group 2 combination lock.

FINISH . . .

- Exterior finish is available in silver gray with polished aluminum control panels.

FITTINGS . . .

- Standard for each Centennial safe (see dimensions table on back).
- All shelves are adjustable.
- Additional security features available as options.

 Underwriters Laboratories approved Class TL 30.

KASO CENTENNIAL SAFES UL TL 30 Burglary Classification

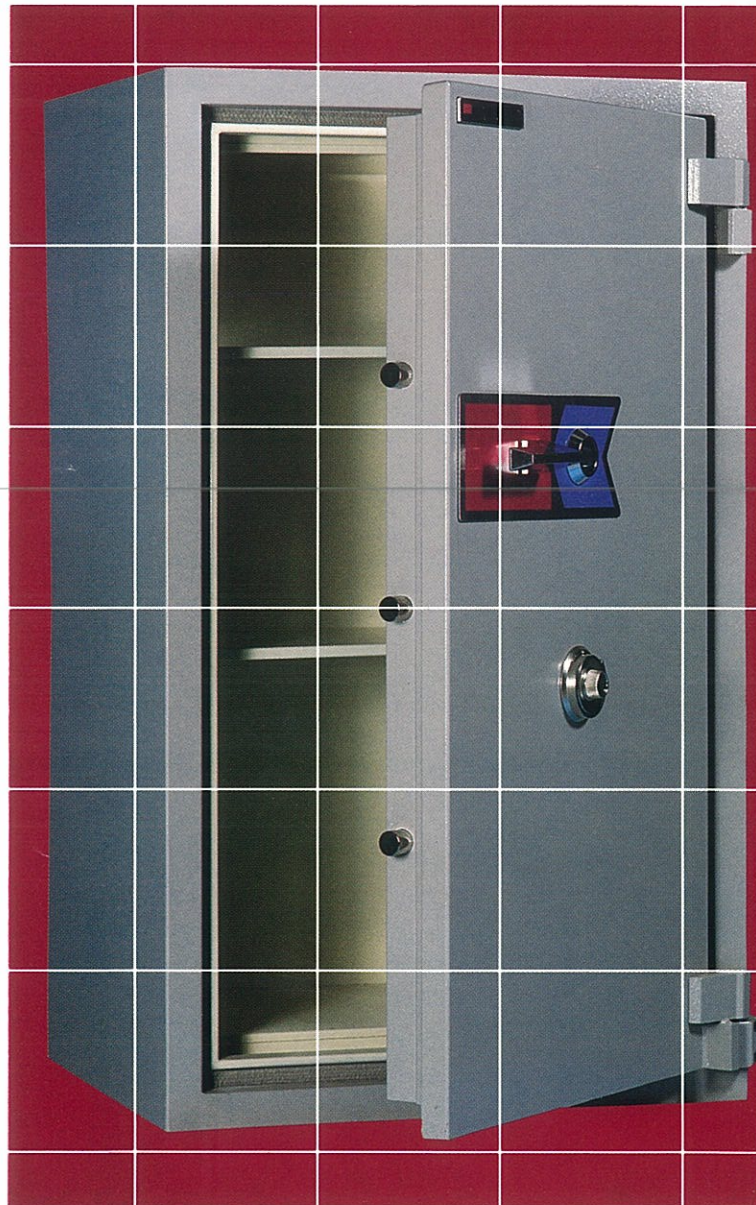

Model 240 C

Since 1891, KASO has been successfully guarding the treasures of the world, providing all-round (six-sided) burglary and fire protection to combat all known forms of attack and conflagration. Officially tested in different parts of the world, KASO products are your guarantee of exceptional protection at remarkably low cost.

KASO CENTENNIAL SAFES UL TL 30

Burglary Classification

SPECIFICATIONS

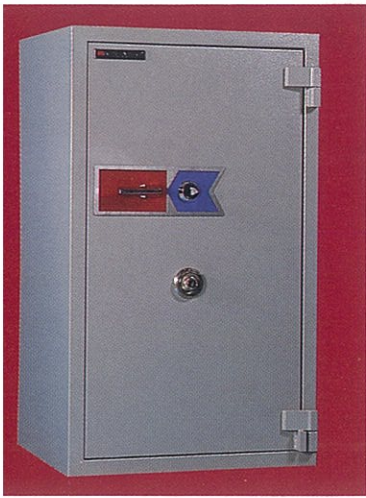

Model 240 C

MODEL	INTERNAL DIMENSIONS			EXTERNAL DIMENSIONS			SHELVES-STANDARD	CUBIC FEET	CUBIC INCHES	WEIGHT-POUNDS
	H	W	D	H	W	D				
225C	21 ³ / ₈ "	19 ¹ / ₈ "	14 ¹¹ / ₁₆ "	29 ¹ / ₂ "	27"	23 ³ / ₁₆ "	1	3.5	6,074	1190
230C	35 ⁷ / ₁₆ "	19 ¹ / ₈ "	14 ¹¹ / ₁₆ "	43 ¹ / ₂ "	27"	23 ³ / ₁₆ "	2	5.7	9,954	1660
240C	45 ¹ / ₄ "	23 ³ / ₁₆ "	16 ¹ / ₄ "	53 ¹ / ₄ "	31 ³ / ₄ "	25 ³ / ₈ "	3	10.1	17,509	2410
250C	59 ¹ / ₁₆ "	23 ³ / ₁₆ "	16 ¹ / ₄ "	67"	31 ³ / ₄ "	25 ³ / ₈ "	4	13.2	22,854	2950
260C	72 ⁷ / ₈ "	27 ¹ / ₁₆ "	20 ³ / ₁₆ "	80 ³ / ₄ "	35 ³ / ₈ "	29 ¹ / ₈ "	5	23.4	40,549	3580
270C	70"	38"	23"	78"	45 ⁷ / ₈ "	32 ¹ / ₁₆ "	5	35.4	61,180	5035

NOTE: Add 2" to external depth for hinge and lock protrusions.

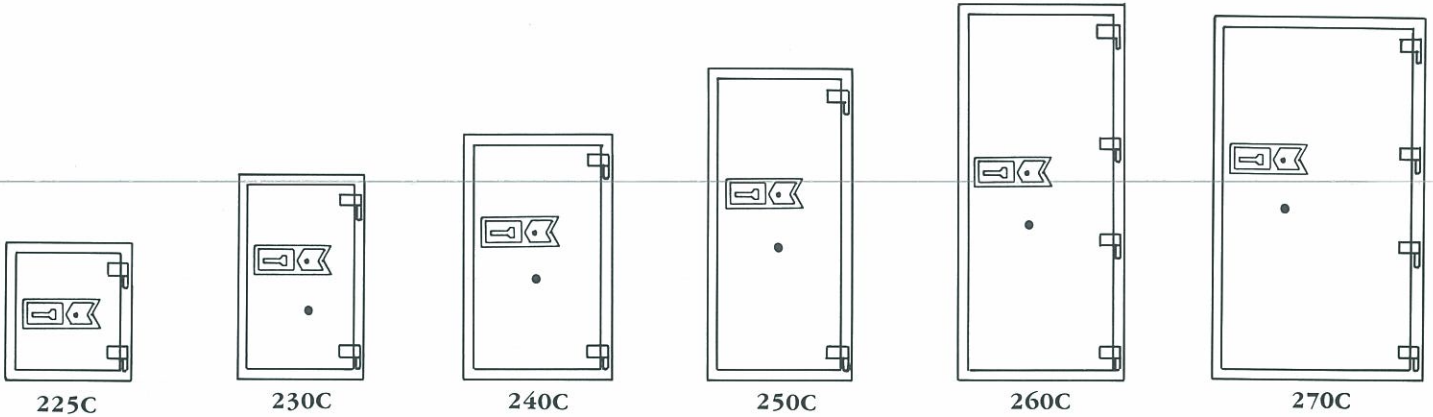

LAYOUT & DIMENSIONS

MODEL	A	B	C	D	E
225C	27"	23 ³ / ₁₆ "	49 ¹⁵ / ₁₆ "	48 ¹ / ₂ "	22 ¹ / ₁₆ "
230C	27"	23 ³ / ₁₆ "	49 ¹⁵ / ₁₆ "	48 ¹ / ₂ "	27 ¹ / ₁₆ "
240C	31 ³ / ₄ "	25 ³ / ₈ "	59 ⁷ / ₈ "	55"	27 ⁷ / ₈ "
250C	31 ³ / ₄ "	25 ³ / ₈ "	59 ⁷ / ₈ "	55"	27 ⁷ / ₈ "
260C	35 ³ / ₈ "	29 ¹ / ₈ "	66 ³ / ₄ "	62 ⁷ / ₁₆ "	31 ³ / ₈ "
270C	45 ⁷ / ₈ "	32 ¹ / ₁₆ "	87 ³ / ₄ "	75 ⁷ / ₈ "	41 ⁷ / ₈ "

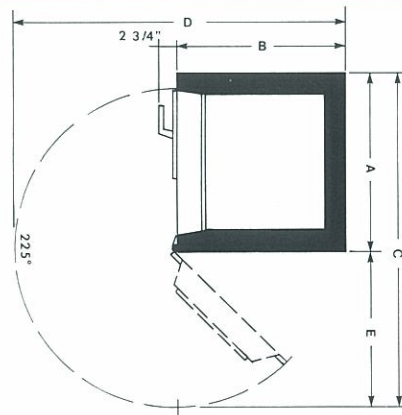

Our policy is one of constant improvement. We therefore reserve the right to incorporate any improvements or alter any specifications without prior notice.